

Features

- Input voltage range: 2.2V–5V (V_{OUT} type)
- Oscillator frequency: 700KHz (Typ.)
- Internal reference: 1.0V (Typ.)
- High efficiency: 93% (Typ.)
- Current limit and thermal shutdown protection
- **Lead-Free** and **Green** Package: SOP-8L (Note 1)

General Description

The AP1635 series are multi-functional step-down DC/DC converters with built-in speed, low ON resistance drivers. It is capable to deliver more than 1.2A output current with external coil, diode and capacitor.

Output voltage is set-up by the external resistors. ($\pm 2.5\%$ accuracy). The 700KHz AP1635 that can work out with small value external components comes out more compact board.

The device switches to and works under PFM mode with light loads. It keeps at high efficiency for both light loads and large output current.

AP1635 can be soft-start with a proper capacitor connected between CE/SS pin and ground. The stand-by current is less than 6uA when CE/SS pin is at "LOW" status. The device is forced to switch off as the voltage at that pin is lower than the stipulated voltage.

Pin Assignments

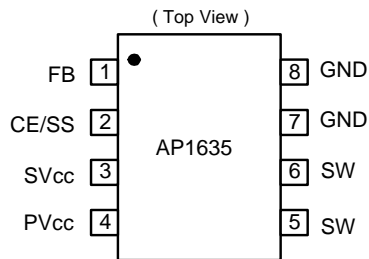

Pin Descriptions

Pin Name	Pin No.	Description
FB	1	Feedback pin
CE/SS	2	Chip Enable/ Soft Start: H: Enable L: Disable
SVcc	3	IC signal power supply pin, add a 20Ω resistor to PVcc and a 0.1μF capacitor to GND.
PVcc	4	IC power supply pin
SW	5/6	Switch Pin. Connect external inductor/diode here. Minimize trace area at this pin to reduce EMI.
GND	7/8	GND Pin

Applications

- Electronic Information Organizers
- Palmtops
- Cellular and portable phones
- Portable Audio Systems
- Various Multi-function Power Supplies

Ordering Information

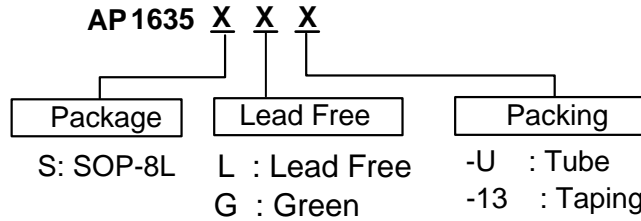

Note: 1. Green is for SOT23 and SC-59.

Device	Package Code	Packaging (Note 2)	Tube or Bulk		-13" Tape and Reel	
			Quantity	Part Number Suffix	Quantity	Part Number Suffix
AP1635S	S	SOP-8L	100	-U	2500/Tape & Reel	-13

Note: 2. RoHS revision 13.2.2003. Glass and High Temperature Solder Exemptions Applied, see *EU Directive Annex Notes 5 and 7*.

Block Diagram

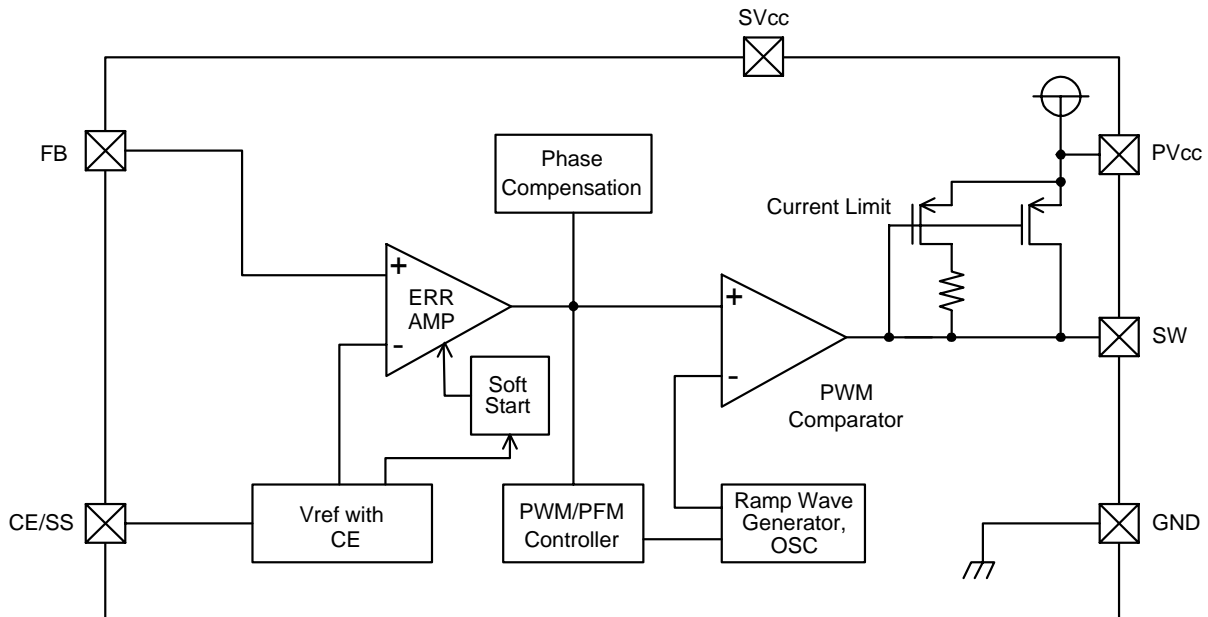

Absolute Maximum Ratings

Ta=25°C

Symbol	Parameter	Ratings	Units
V _{CC} /SV _{CC}	V _{IN} Pin Voltage	-0.3 ~ 5.0	V
V _{SW}	SW Pin Voltage	-0.3 ~ V _{IN} +0.3	V
V _{FB}	FB Pin Voltage	-0.3 ~ V _{IN} +0.3	V
V _{CE/SS}	CE/SS Pin Voltage	-0.3 ~ V _{IN} +0.3	V
P _D	Continuous Total Power Dissipation	Internal limited	
T _{opr}	Operating Ambient Temperature	-25 ~ +80	°C
T _{stg}	Storage Temperature	-40 ~ +125	°C

Electrical Characteristics

V_{IN}=5V, V_{OUT}=2V, Load=300mA, T_A=25°C

Sym.	Parameter	Conditions	Min.	Typ.	Max.	Units
V _{FB}	FB		0.975	1.0	1.025	V
V _{IN}	Input Voltage		2.2	-	5	V
	Line Regulation	V _{IN} =2.2~5V, Load=10mA	-	-	0.12	%
	Load Regulation	I _{OUT} =10~1200mA	-	-	1.2	%
V _{UVLO}	UVLO Voltage (min. operating voltage)	V _{CC} , voltage required to maintain H at V _{OUT}	-	-	2	V
I _{CC}	Operating Current	CE/SS=V _{IN} , No Load	-	100	150	μA
I _{CCQ}	Supply Current	No external components, CE/SS=V _{IN} , V _{FB} =1.2V	-	90	120	μA
I _{STB}	Stand-by Current	No external components, CE/SS=0V, V _{FB} =0V	-	6	-	μA
I _{CL}	Current Limit	Peak current V _{IN} =5V, V _{OUT} =2V	1200	1400	1600	mA
F _{OSC}	Oscillator Frequency	Load=300mA, V _{IN} =5V, V _{OUT} =2V	500	700	-	kHz
MAXDTY	Maximum Duty Ratio		85	90	-	%
PFMDTY	PFM Duty Ratio	No load	15	25	35	%
V _{CEH}	CE/SS "High" Voltage	Apply 1.4V (min.) to CE/SS, determine V _{OUT} "High"	1.4	-	-	V
V _{CEL}	CE/SS "Low" Voltage	Same as V _{CEH} , determine V _{OUT} "Low"	-	-	0.6	V
EFFI	Efficiency	V _{CC} =5V, V _{OUT} =3.3V, Load=300mA	-	93	-	%
R _{dson}	R _{dson} Condition	I _{OUT} =300mA, V _{IN} =5V, V _{OUT} =2V	-	350	450	mΩ

Typical Performance Characteristics

Vcc vs. Operating Current

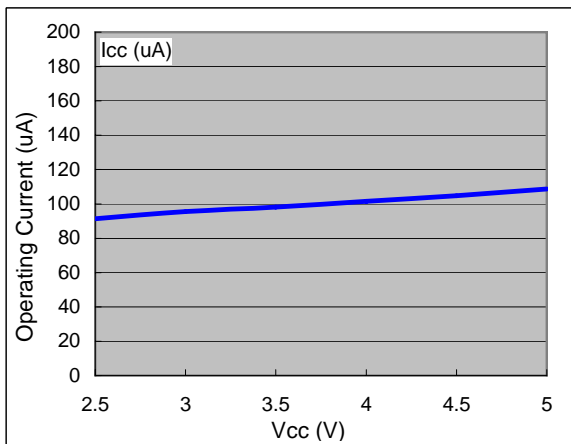

Vcc vs. Quiescent Current

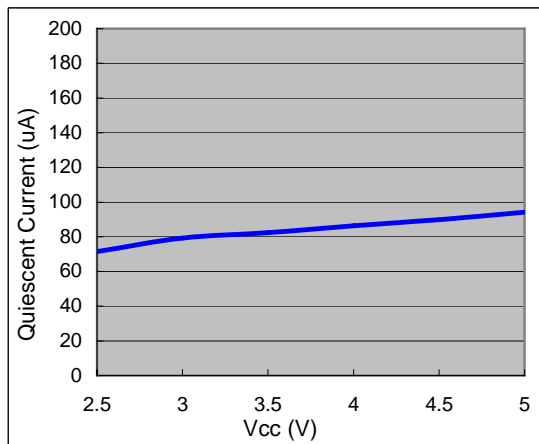

Vcc vs. Stand-by Current

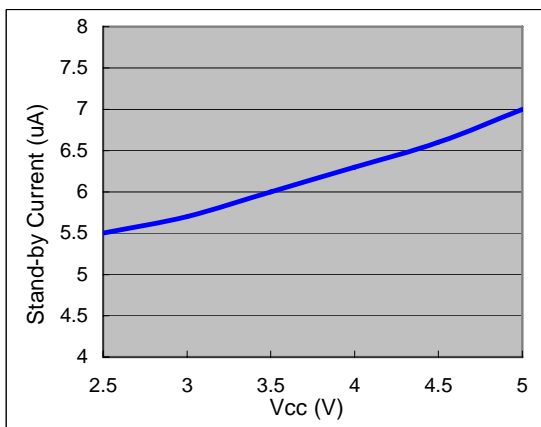

Vcc vs. Frequency

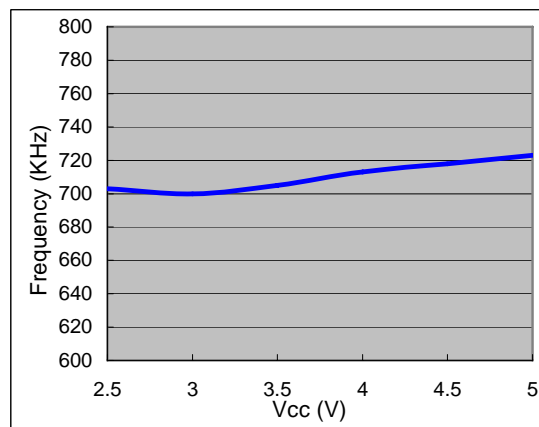

Vcc vs. Current Limit

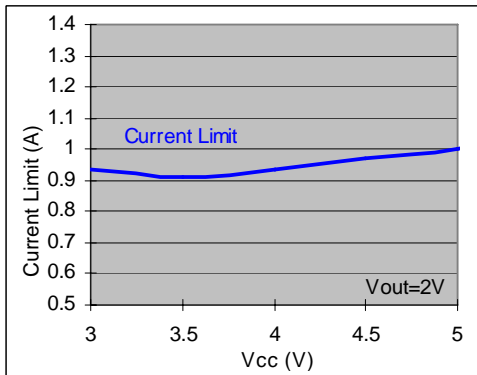

Vcc vs. R_{DS(ON)}

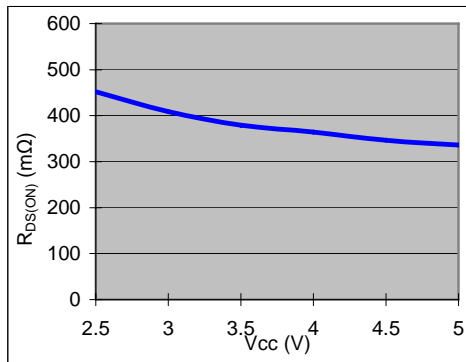

Typical Performance Characteristics (Continued)

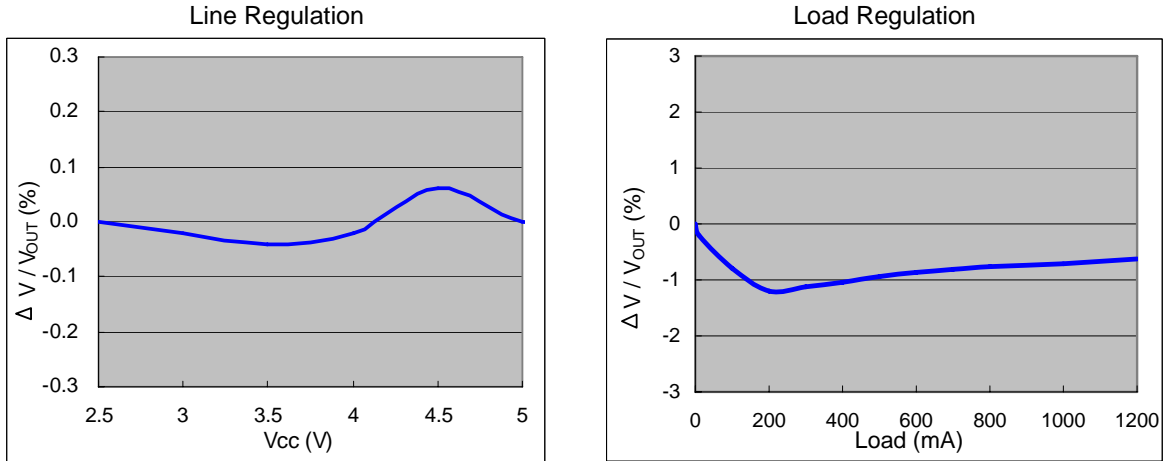

Typical Application Circuit

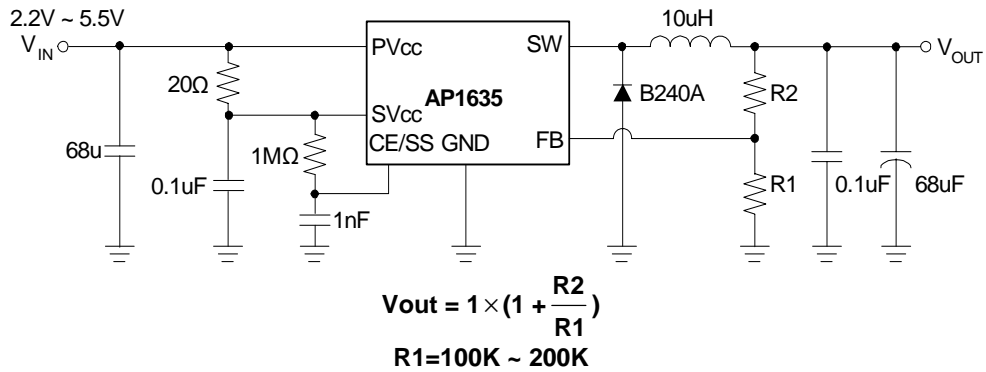

Marking Information

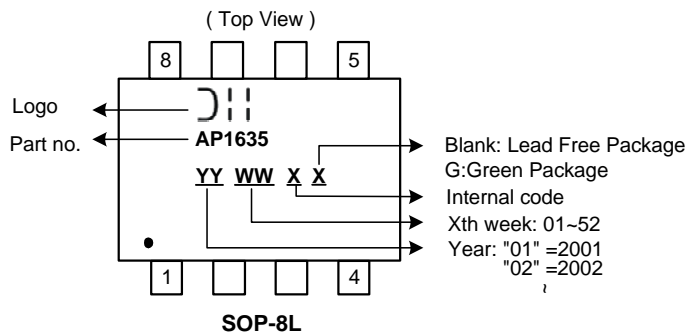

Package Information

Package Type: SOP-8L

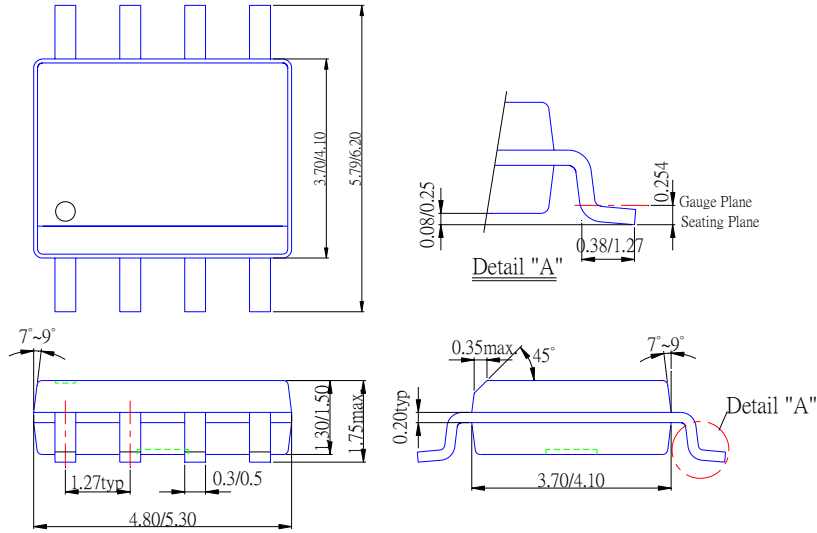

IMPORTANT NOTICE

Diodes Incorporated and its subsidiaries reserve the right to make modifications, enhancements, improvements, corrections or other changes without further notice to any product herein. Diodes Incorporated does not assume any liability arising out of the application or use of any product described herein; neither does it convey any license under its patent rights, nor the rights of others. The user of products in such applications shall assume all risks of such use and will agree to hold Diodes Incorporated and all the companies whose products are represented on our website, harmless against all damages.

LIFE SUPPORT

Diodes Incorporated products are not authorized for use as critical components in life support devices or systems without the expressed written approval of the President of Diodes Incorporated.